



Engineered  
in Italy

**NEW**  
**5 BUSBAR**

**FU 315 / 320 / 325 / 330 M NEXT**  
Monocrystalline Photovoltaic Module - 60 cells



**GENERAL FEATURES**

- **15-year product warranty**
- **Bigger high-efficiency PERC cells** optimized for low irradiance, decrease ohmic losses and increase the yield
- **Increased power up to 10%** on standard dimensions
- **Higher yield at low irradiance**
- For installations **up to an altitude of 7000 m**
- Maximum **resistance against hail** (83 km/h)
- Quality control with **electroluminescence (EL) tests** on each module

**CERTIFICATIONS**

- › **IEC 61215:2016 - IEC 61730:2016 & Factory Inspection\***
- › **Fire Resistance - Class 1**
- › **Salt Corrosion Resistance** IEC 61701
- › **Ammonia Corrosion** IEC 62716
- › **Dust and Sand Resistance** IEC 60068-2-68

**NEW**

**GUARANTEES**

**Performance guarantee**

Max power decrease **0.5%/year**  
97% at the end of first year  
**90% at the end of 20<sup>th</sup> year**  
87% at the end of **25<sup>th</sup> year**

**Product guarantee**

**15 YEARS**

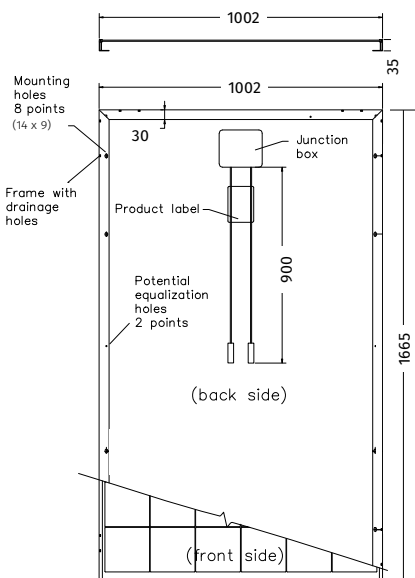
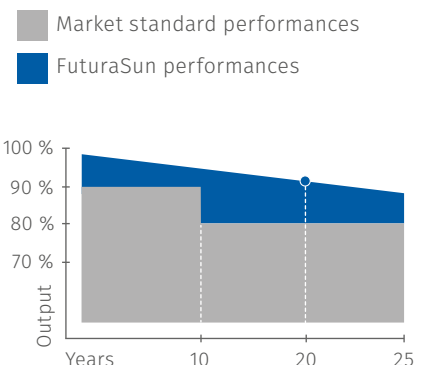

Note: dimensions in mm  
tolerance +/- 2 mm

## ELECTRICAL DATA

MODULE NEXT		FU 315 M	FU 320 M	FU 325 M	FU 330 M
<i>Standard Test Conditions STC: 1000 W/m<sup>2</sup> - AM 1.5 - 25 °C - tolerance: Pmax (±3%), Voc (±4%), Isc (±5%)</i>					
Module power (Pmax)	W	315	320	325	330
Open circuit voltage (Voc)	V	41.02	41.24	41.44	41.66
Short circuit current (Isc)	A	9.8	9.88	9.96	10.04
Maximum power voltage (Vmpp)	V	33.42	33.68	33.93	34.17
Maximum power current (Impp)	A	9.43	9.51	9.58	9.66
Module efficiency	%	18.81	19.18	19.48	19.78

*Nominal Module Operating Temperature NMOT: 800 W/m<sup>2</sup> - T=45 °C - AM 1.5*

Module power (Pmax)	W	231.33	235.11	238.60	242.29
Open circuit voltage (Voc)	V	37.83	38.04	38.22	38.43
Short circuit current (Isc)	A	8.06	8.12	8.19	8.26
Maximum power voltage (Vmpp)	V	30.25	30.48	30.71	30.92
Maximum power current (Impp)	A	7.65	7.71	7.77	7.84

## TEMPERATURE RATINGS

Temperature coefficient Isc	%/°C	0.0344
Temperature coefficient Voc	%/°C	-0.273
Temperature coefficient Pmax	%/°C	-0.389
NMOT **	°C	45
Operating temperature	°C	from -40 to +85

\* Certification on going

\*\* Nominal Module Operating Temperature

## MECHANICAL SPECIFICATIONS

Dimensions	1665 x 1002 x 35 mm
Weight	18.4 kg
Glass	Tempered, transparent, 3.2 mm
Cell encapsulation	EVA (Ethylene Vinyl Acetate)
Cells	60 monocrystalline PERC cells 158.75x158.75 mm
Backsheet	Composite multilayer film
Frame	Anodized aluminium frame with mounting and drainage holes
Junction box	Certified according to IEC 62790, IP 68 approved
Cables	Solar cable, length 900 mm assembled with MC4-combinable plugs
Maximum reverse current (Ir)	20 A
Maximum system voltage	1000 V (1500 V on request)
Maximum load (wind/snow)	5400 Pa (including safety factor 1.5)
Protection Class	II - accordance to IEC 61730

Authorized Dealer



**Wagner Solar**

2002 óta

[www.wagnersolar.hu](http://www.wagnersolar.hu)



**FuturaSun srl**

Riva del Pasubio, 14 - 35013 Cittadella - Italy  
Tel + 39 049 5979802 Fax + 39 049 0963081  
[www.futurasun.com](http://www.futurasun.com) - [info@futurasun.it](mailto:info@futurasun.it)